

# CROWN OPTO X2



Balt led



## ITEM DESCRIPTION



With Crown OPTO X2 we introduce a new member for Crown OPTO family for one-sided signs. Designed for depths ranging from 100 to 160 mm, these modules also enable you to reduce installation time and save up on module quantity. As they can be installed with 230 mm step, you need 22% less modules for 1 m<sup>2</sup> than with previous solutions. Powered by Philips Lumiled, they show extreme endurance at harsh working conditions (IP67) and have 7 year warranty with L70 for 80,000 hours.

## APPLICATION

- One-sided signs and light boxes
- Recommended depth 100 – 160 mm
- Red, green and blue colours available

## FEATURES & BENEFITS

- Powered by Philips Lumiled
- CRI > 83
- Extreme environment and conditions housing
- Easy and fast installation cables
- Made in Europe
- IP67 protection class
- 7 year warranty

## GENERAL SPECIFICATIONS

SUPPLY VOLTAGE	12 VDC
POWER	0.8; 1.0 W
RECOMMENDED DEPTH	From 100 to 160 mm
CC DISTANCE	230 mm
BINNING	3 SDCM
OPERATING TEMPERATURE	-40 °C ~ +60 °C
STORAGE TEMPERATURE	+5 °C ~ +35 °C
STORAGE CONDITIONS	Relative humidity <60%
LIFETIME	L70 80,000 h (white) L70 60,000 h (other)
WARRANTY	7 years*

\*Warranty is applied only and if storage, mounting and maintenance conditions, stated in the installation guide, are followed.

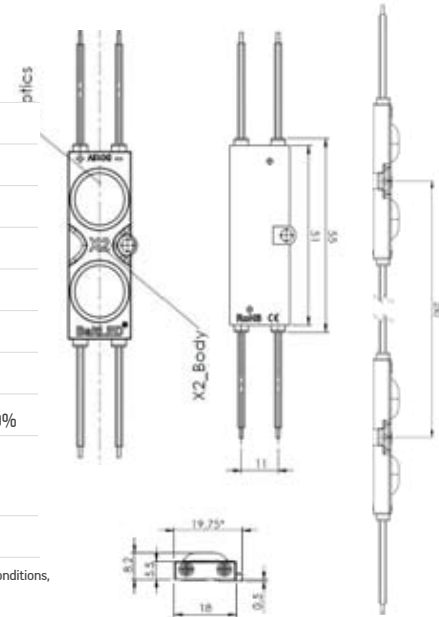

\* Dimensions are in mm

## LIGHT DISTRIBUTION GRAPH

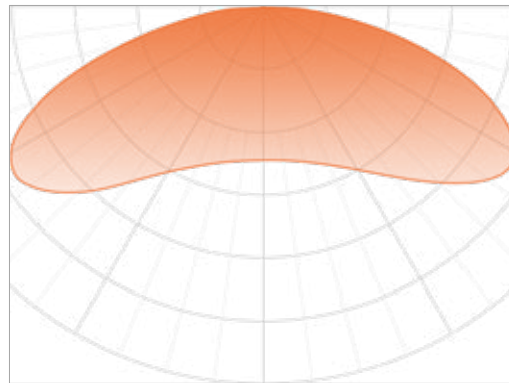

Beam angle: 160°

## ORDERING INFORMATION

SKU	POWER, W	LUMEN OUTPUT, LM	COLOUR
BMP-X2.2-02UH160CW65NS	1.0	102	6500 K
BMP-X2.2-02UH160NW40NS	1.0	102	4000 K
BMP-X2.2-02UH160WW30NS	1.0	92	3000 K
BMP-X2.2-02UH160RC	0.8	34	red
BMP-X2.2-02UH160GC	1.0	70	green
BMP-X2.2-02UH160BC	1.0	18	blue

CHAIN	BAG	BOX
50 pcs (net weight: 0.667 kg)	100 pcs (net weight: 1.36 kg)	600 pcs (net weight: 8.5 kg)

© 2018, All rights reserved BaltLED, UAB. Specifications are subject to change without notice.